

EN



Catalogue of parts and assemblies for air heater AUTOTERM Air 2D

АДВР.320.01.00.000 КДС

Manufacturer: ADVERS LLC

Novo-Sadovaja str. 106, 443068, Samara, Russia

www.autoterm.ru

Representative office of manufacturer: AUTOTERM LLC

Paleju 72, Marupe, Latvia, LV-2167

Warranty Department warranty@autoterm.com

Technical Support service@autoterm.com

www.autoterm.com

This part-and-assembly catalogue is intended for companies and individuals involved in installing, repairing, and maintaining air heater Autoterm Air 2D.

This catalogue consists of two sections:

1. A schematic drawing of the **air heater** (figure 1) and a list of the air-heater's parts and assemblies (table 1)
2. A schematic drawing of the **heater** (figure 2) and a list of the heater's parts and assemblies (table 2)

If a part or assembly fails during use, look up its designation in this catalogue to order a replacement from the manufacturer.

IMPORTANT **For ease of ordering, use the manufacturer's product numbers listed in the tables below**

Table 1

№	Part/assembly description and designation		Notes	Air 2D (24V) assy 4740	Air 2D assy 4745	Air 2D (24V) assy 5125	Air 2D assy 5130
				1	2	3	4
	Air heater number			1	2	3	4
1	Heater						
	assy 4741	24V		1		1	
	assy 4746	12V			1		1
2	Fuel intake						
	assy 807			1	1	1	1
3	Fuel pump						
	P0637 24V	Thomas Magnete		1			
	P0636 12V	Thomas Magnete			1		
	assy 4997	TH11-4,4ml-24V				1	
	assy 4995	TH11-4,4ml-12V					1
7	Fuel pump harness						
	assy 2061			1	1	1	1
8	Control panel harness						
	assy 2067			1	1	1	1
10	Muffler						
	assy 3944			1	1	1	1
11	Air intake						
	assy 2552			1	1	1	1
12	Power supply harness						
	assy 4007	24V		1		1	
	assy 3647	12V			1		1
15	Air intake mounting kit						
	assy 9021			1	1	1	1
16	Mounting kit of exhaust pipe and heating						
	assy 9022			1	1	1	1
17	Mounting kit of fuel system						
	assy 9049			1	1	1	1
18	Mounting kit for harnesses						
	assy 9050			1	1	1	1
20	Fuel supply line						
	det. 879	L=5,5 m		1	1	1	1
22	Metal hose						
	det. 1106	L=1 m		1	1	1	1
23	Duplicate of label						
	det. 5098			1		1	
	det. 5099				1		1
48	Heat insulation (28x5x450)			1	1	1	1

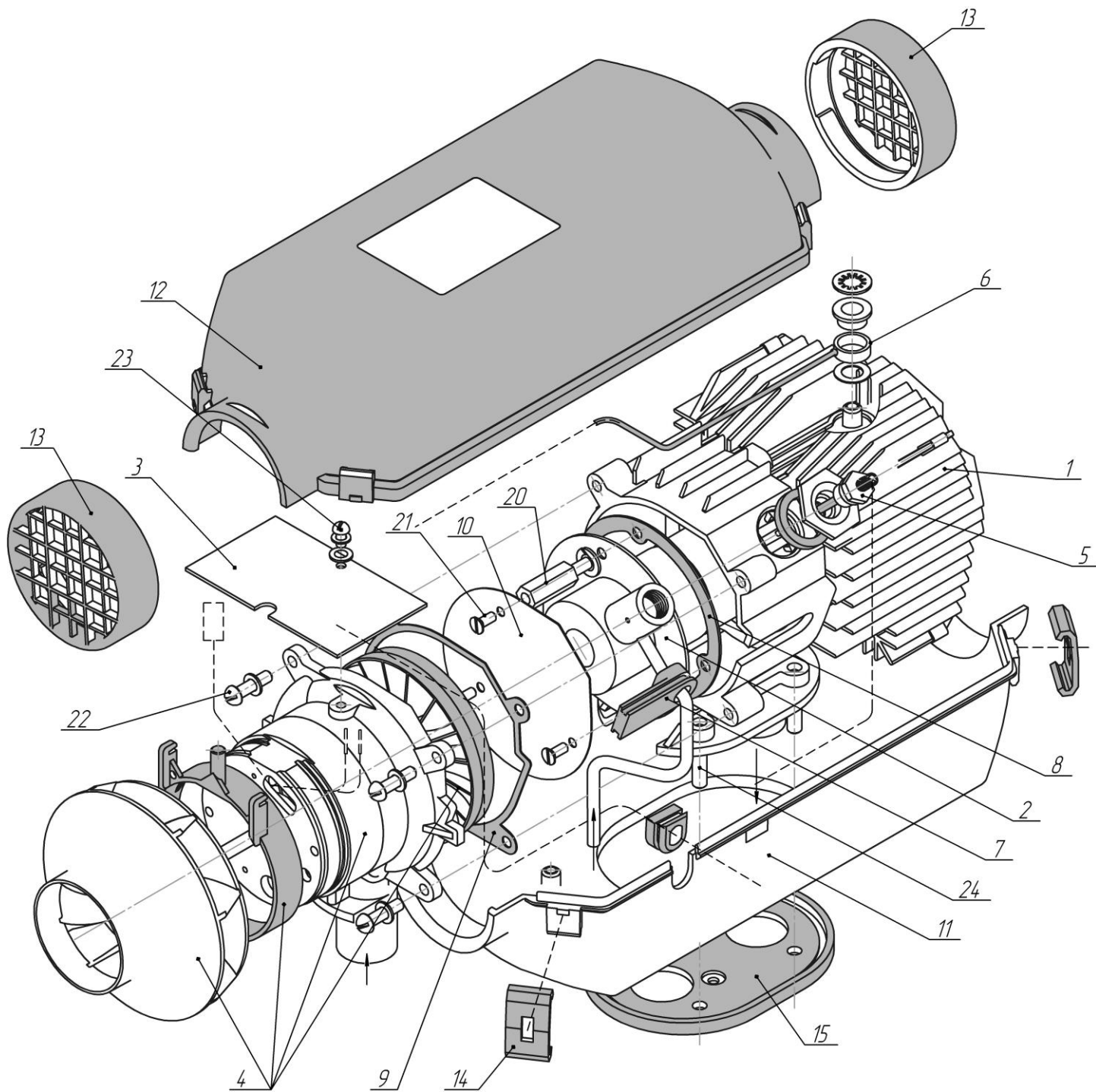

Figure 2- Schematic drawing of the heater

Table 2

No	Part/assembly description and designation	Notes	assy 4741	assy 4746
	Heater number		1	2
1	Heat exchanger			
	det. 4055		1	1
2	Combustion chamber			
	assy 2578		1	1
3	Control unit			
	assy 4223		1	
	assy 3983			1
	det.1070	gasket		
4	Air pump			
	assy 2579	24V	1	
	assy 2613	12V		1
5	Glow plug assembly			
	assy 2583	24V	1	
	assy 2615	12V		1
	det. 2822	Sealing sleeve	1	1
	det. 2659	Metallic sleeve	1	1
6	Temperature sensor assembly			
	assy 3076	Temperature sensor	1	1
	det. 3939	Washer (mica)	1	1
	det. 2661	Insulator	1	1
	Bolt M5x10 DIN 75000CE		1	1
	Washer Ø5	King size	1	1
	Spring washer Ø8 DIN 137		1	1
7	Fuel pipe sealing			
	det. 2658		1	1
8	Combustion chamber gasket			
	det. 2655		1	1
9	Air pump gasket			
	det. 2656		1	1
10	Shield			
	det. 2967		1	1
11	Bottom enclosure			
	det.2647	with gasket det. 2651 (2 pieces)	1	1
12	Top enclosure			
	det.2648	with gasket det. 2651 (2 pieces)	1	1
13	Grid			
	det. 2649		2	2
14	Grips			
	det.1683		4	4
15	Enclosure sealing			
	det. 2650		1	1
20	Combustion chamber fixing			
	det. 2905		3	3
	Lock washer Ø5		3	3

№	Part/assembly description and designation	Notes	assy 4741	assy 4746
	Heater number		1	2
21	Shield fixing			
	Screw M4x10 DIN965		3	3
22	Air pump fixing			
	Screw M5x20 DIN 7500 CE		4	4
	Lock washer Ø5		4	4
23	Control unit fixing			
	Screw M4x10 DIN 7500 CE		1	1
	Lock washer Ø4		1	1
24	Studs			
	M6x18		3	3
	M6x20 DIN 939		1	1